

Pakowarka próżniowa seria SE 200, 300, 400, 500 1140622, 1140628, 1140636, 1140642

(wersja 2018/02/20/MW)

SE-200

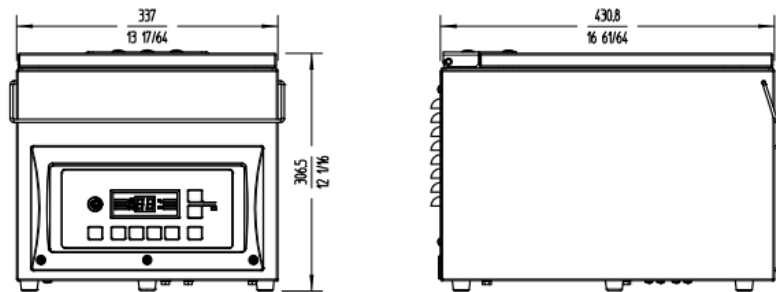

SE-300

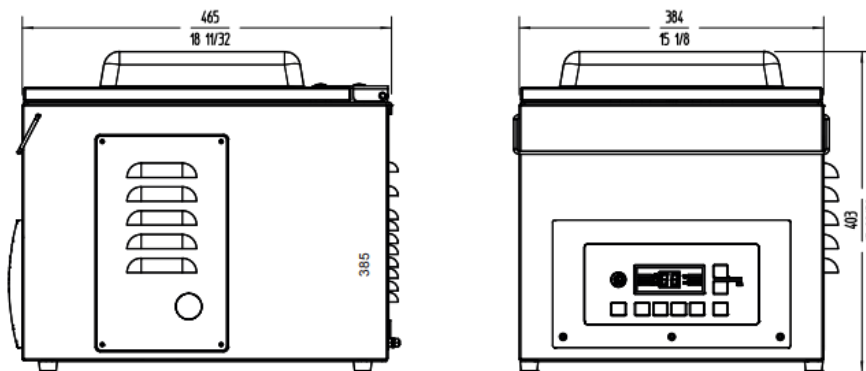



GRAFEN
FUTURE EQUIPMENT

SE-410

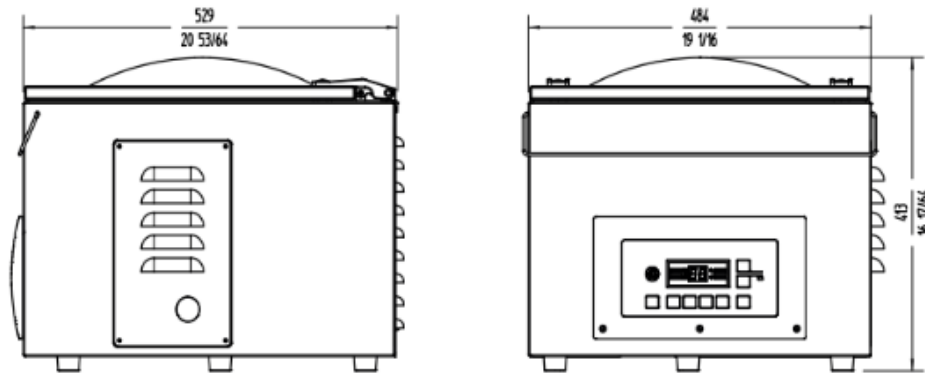

SE-520

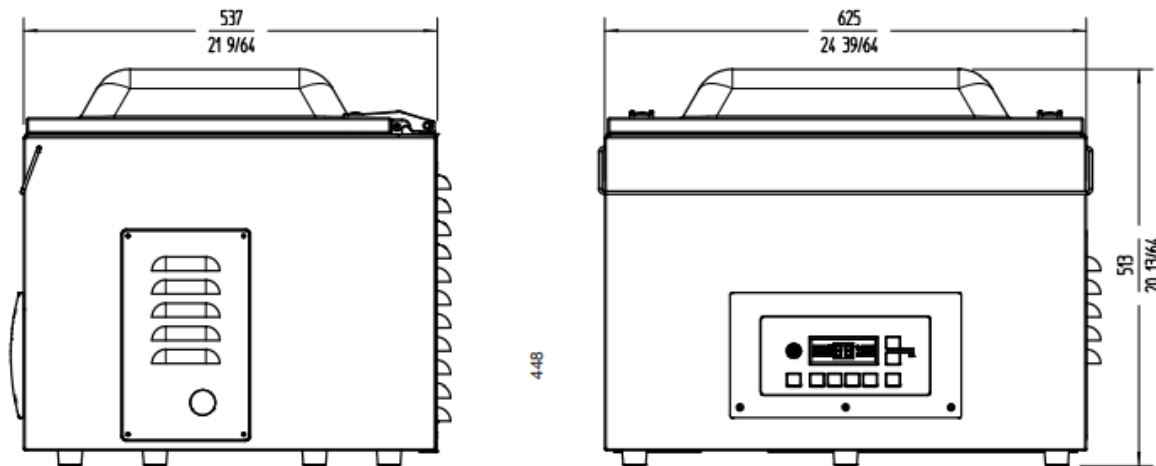



Kod producenta:	1140622	1140628	1140636	1140642
Model	SE-206	SE-310	SE-416	SE-520
Wymiary zewnętrzne [mm]	337x431x(H)307	384x465x(H)403	484x529x(H)448	625x537x(H)513
Wymiary komory [mm]	288x334x(H)111	330x360x(H)155	430x415x(H)180	560x430x(H)183
Rodzaj komory	Tłoczona	Tłoczona	Tłoczona	Spawana
Długość listwy grzewącej	280 mm	320	420 mm	420+420 mm
Ułożenie listw grzewących w komorze				
Grubość i ilość zgrzewów	2x 3mm	2x 3mm	2x 4mm	2x 4mm
Wydajność pompy próżniowej BUSCH	6 m ³ /h	10 m ³ /h	16 m ³ /h.	20 m ³ /h.
Maks. Ciśnienie próżni [mbar]	2	2	2	2
Moc [W]	370	370	550	750
Napięcie	230 V / 50-60 Hz			
Waga [Kg]	26	34	65	80